

JVM800R

VACUUM MANIPULATOR



Lifting capacity

800 kg



Powered by

Battery



Weight

220 kg

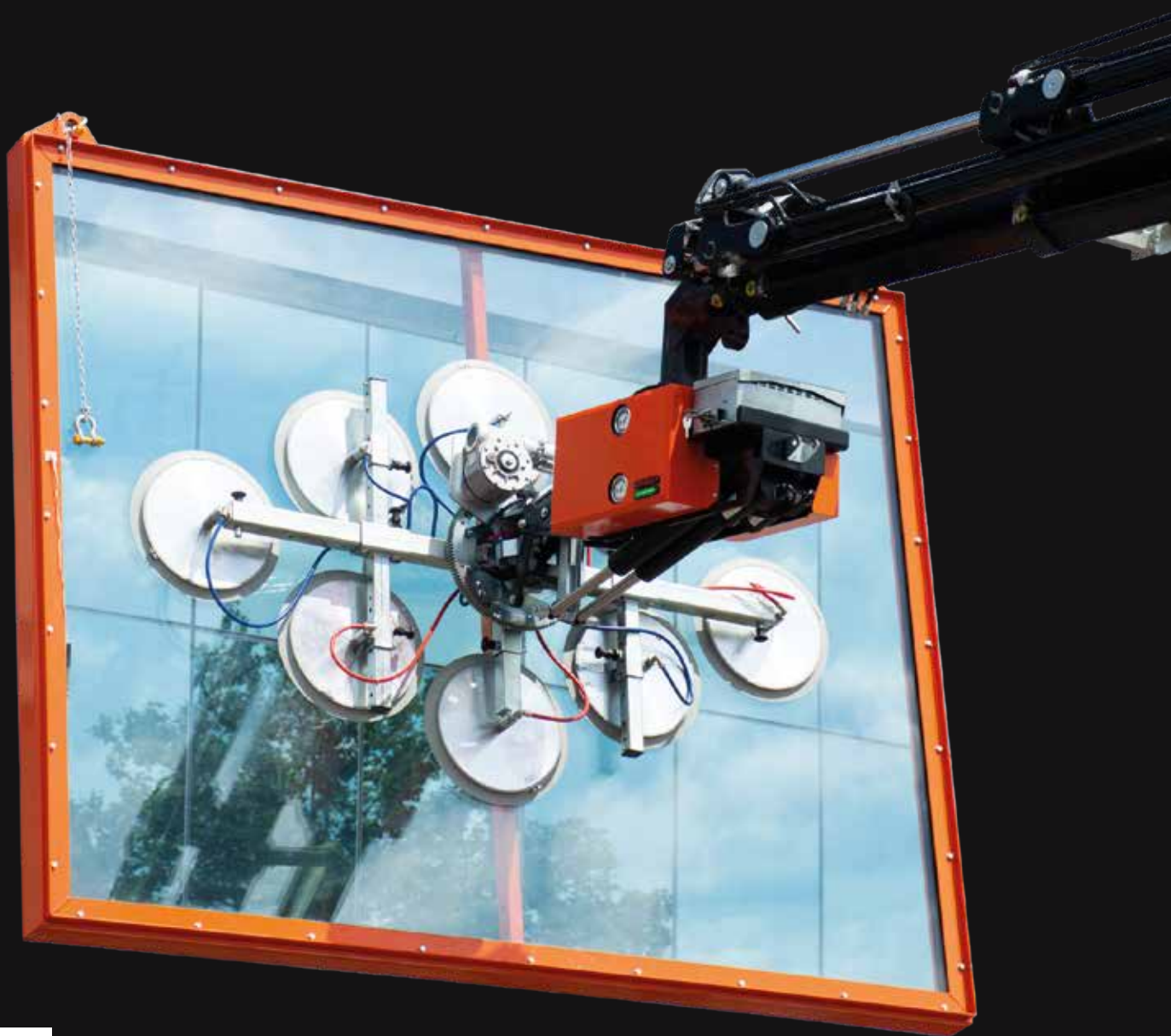

EN [m - kg]

DIMENSIONS_(mm)

MOVEMENTS

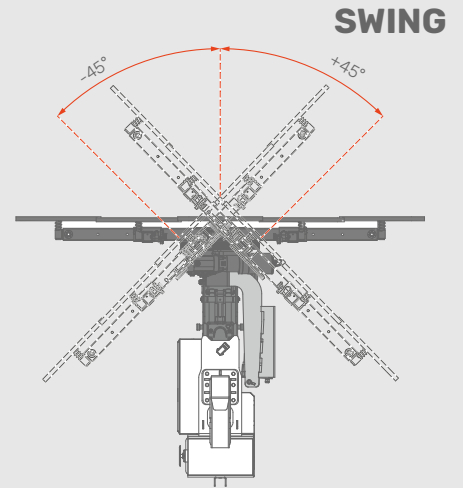
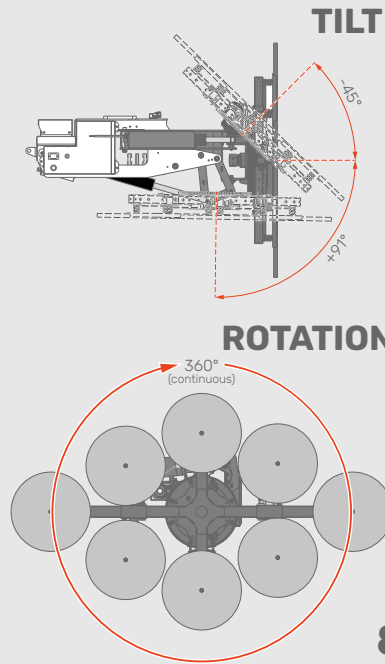
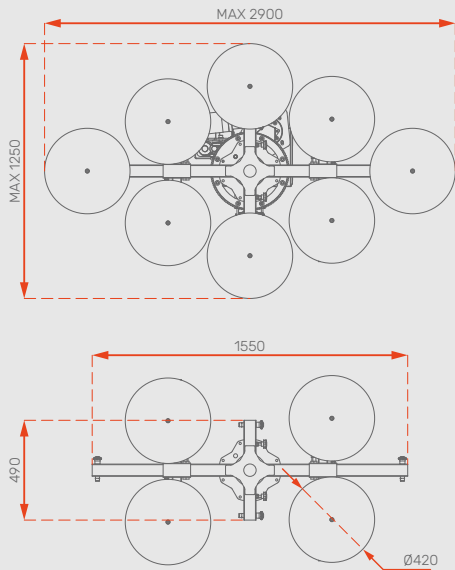

800KG LIFTING CAPACITY
(8 PADS INSTALLED)

STAND ALONE FOR ANY CRANE

- Universal tool for any crane
- Independent vacuum system
- Independent battery
- Independent radio remote control



WIDE MOVEMENTS RANGE

- 360° continuous rotation
- Wide swing: +45° / -45°
- Wide tilt: +91° / -45°



FLEXIBLE CONFIGURATION

- 8 - 6 - 4 pads with modular layout
- Adaptable pads position
- Pads for glass, marble, slabs and sandwich panels



SAFE LIFTING

- Two independent vacuum circuits
- Vacuum pump onboard
- Safety vacuum seal
- "Blow-off" function for easy release



BATTERY POWERED

- Runtime over one workday
- Spare battery on transport tray
- Battery charging dock



TRANSPORT TRAY

- Practical and sturdy
- Easy to install
- Big tool box



*Optional



JVM800R
VACUUM MANIPULATOR

Jekko s.r.l. • info@jekko.it • www.jekko-cranes.com

Specifications are subject to change without notice.

All data provided is for reference purposes only and is not legally binding.